

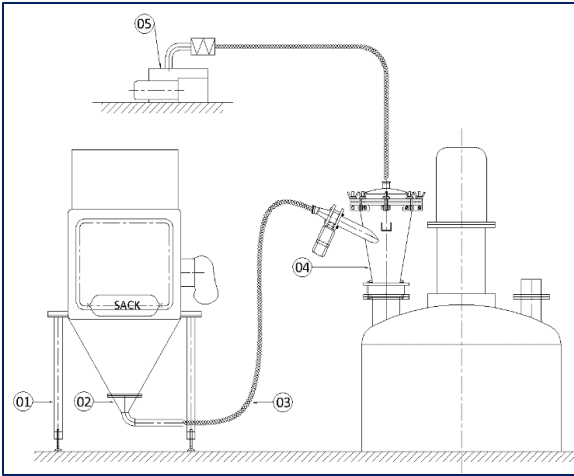

1 - MATERIAL HANDLING SYSTEMS – POWDER, GRANULES CONVEYING VIA VACUUM TRANSFER SYSTEM

- **MAXIMISE PRODUCT TRANSFER WHILE ELIMINATING LOSS THROUGH PNEUMATIC CONVEYING**



POWDER TRANSFER THROUGH SACK DISCHARGE STATION

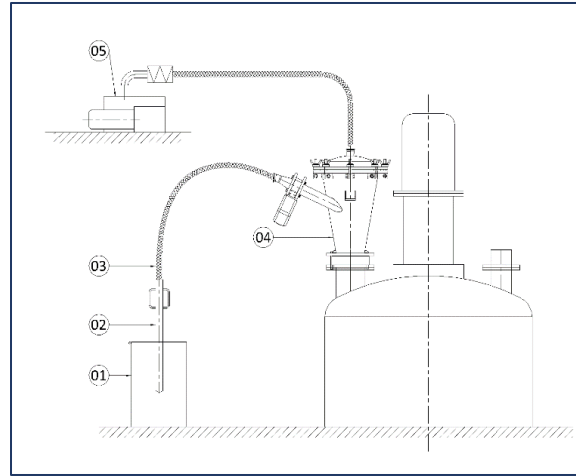

POWDER TRANSFER THROUGH DRUM

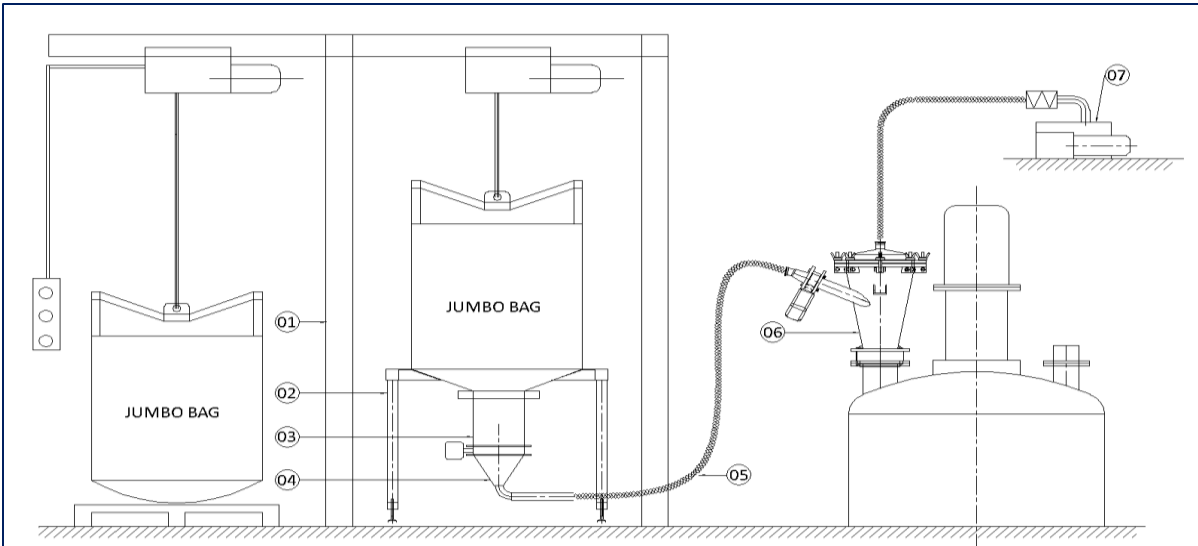

POWDER TRANSFER THROUGH BIG BAG CHARGING STATION

Materials are drawn to the delivery point through a totally enclosed pipeline – via vacuum conveying, in a clean, contained stream of air generated by a vacuum blower package - no moving parts contact the materials, no dust escapes into the atmosphere and no contamination can enter the system.

ADVATAGES OF VACUUM CONVEYING - *EFFICIENCY+SAFETY+HYGIENE+COST EFFECTIVNESS+FLEXIBILITY-AUTOMATION+NO CONTAMINATION+DUST FREE OPERATION*

ELEMENTS OF A VACUUM CONVEYING SYSTEM

- **Material Pick Up** – From Suction wands from free flowing materials – Silo Pickup, Big bag dumping stations with prefeeders for powders
- **Conveying line** – Connecting one or more multiple pickup stations to a vacuum receiver. To ensure baggage free conveying – Diverter valves and line clearance valves, are available in addition to the piping.
- **Various models receivers** are available to separate the material from the conveying air stream, alternating between suction and discharge modes of operation.
- **Sequence & Vent Valves** - allow the air stream to bypass and vent the vacuum receiver during the discharge cycle.
- **Blower Packages** - include the pump -PD blower, sliding vane or rotary lobe blower- to produce the air stream as well a bypass valve to allow the blower to run while no receiver is conveying and a secondary filter to protect the vacuum pump from entrance of foreign bodies.
- **Controls** -to control a single central or self-contained unit and sequence of a multi-component system with PLC and HMI. Siemens, Mitsubishi and Allen Bradley



2 -MATERIAL HANDLING SYSTEMS – POWDER, GRANULES CONVEYING VIA VACUUM TRANSFER SYSTEM

Batch and Continuous

To achieve process efficiency, changeover times and, of course, ensure product safety, one of the key technologies that can help address and improve these factors is pneumatic conveying, regardless of - transfer from bulk storage to process - check screening of raw materials - mixer loading and unloading

PCS represents an ideal solution for meeting the easiest transfer of material by generating and maintaining vacuum in the system. The 100% material can be easily transferred from one process to another in time with minimum engagement of human resources. This system offers safety and hygiene - cGMP compliant

- Pneumatically operated , closed system for dust free operation for powder or granules , wet and dry products with considerable reduction and elimination exposure to operator
- To avoid choking and aid to continuous feeding of product , buffer vessel is provided
- Filter cleaning via pulsing method – increasing efficiency
- Eliminates lifting and loading device and other handling equipment's and thus reducing saving useful resources
- Controls in Semi –Automatic and fully automatic via HMI PLC with 21CFR C 11 compliance

Click to add text

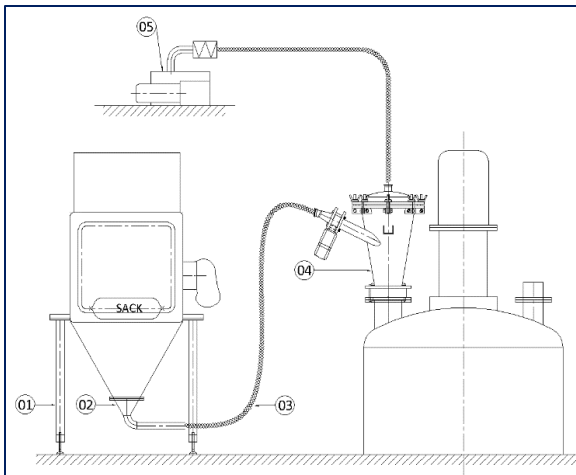
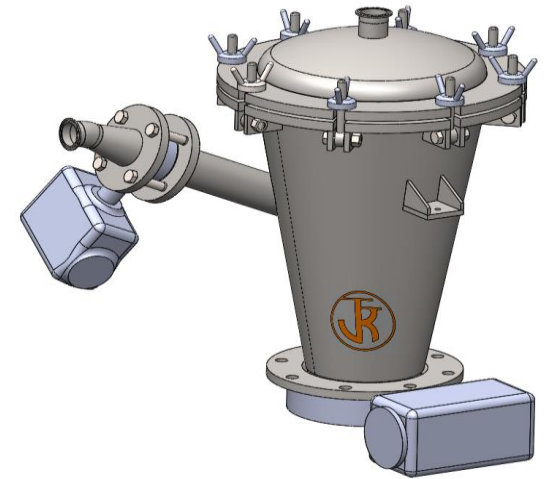

POWDER TRANSFER THROUGH SACK DISCHARGE STATION

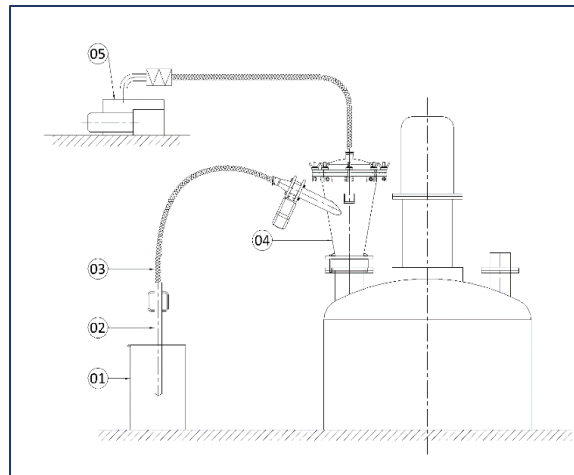

POWDER TRANSFER THROUGH DRUM

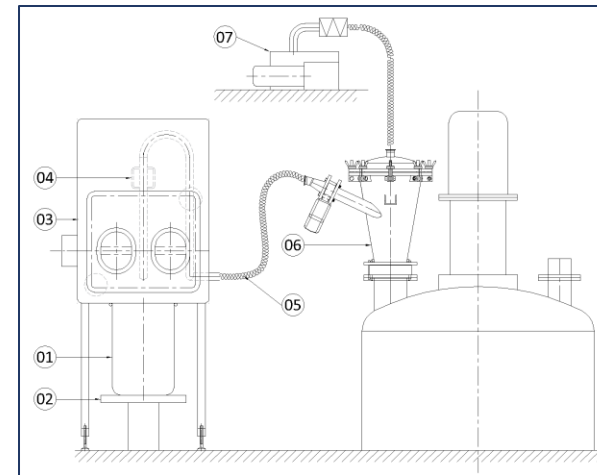

POWDER TRANSFER – CONTAINED DRUM CHARGING



3 -MATERIAL HANDLING SYSTEMS – POWDER, GRANULES CONVEYING VIA VACUUM TRANSFER SYSTEM

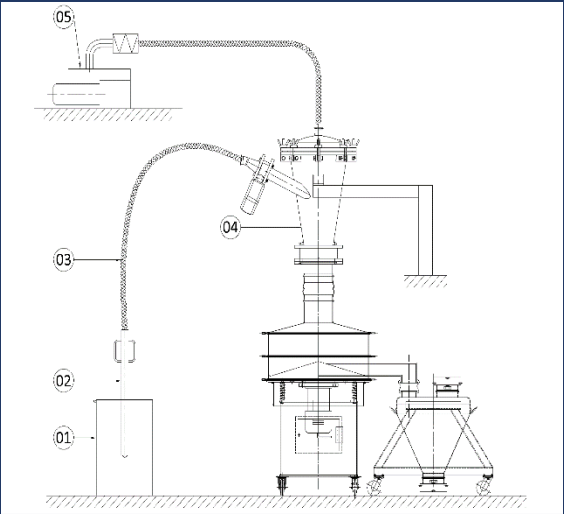

POWDER TRANSFER FOR SIEVING

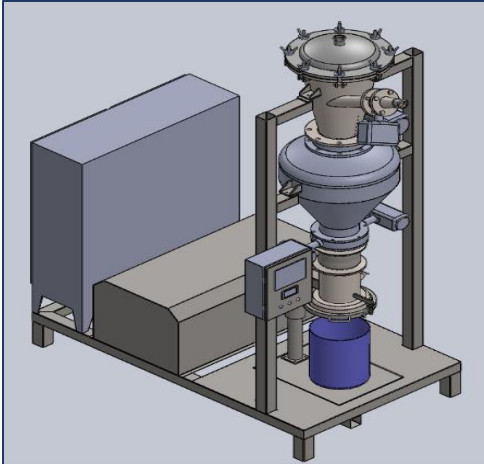

SEMI/FULLY AUTOMATIC DRUM FILLING STATION WITH WEIGHMENT AND DISCHARGE WITH INTERLOCKING SYSTEM
PACKING TO CARBHOY/HDFE DRUMS/LINER BAGS

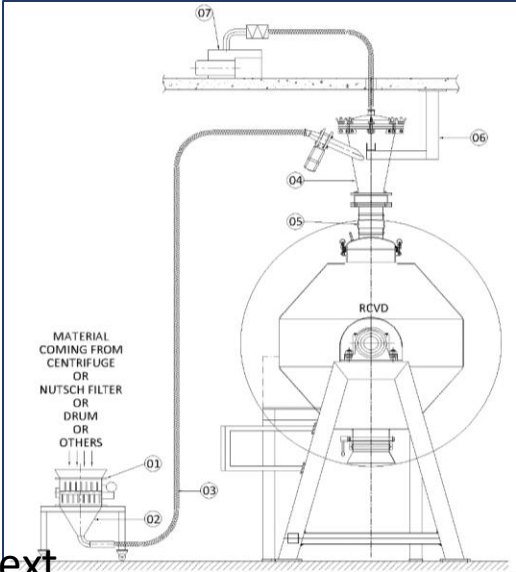

RCVD DISCHARGE VIA VACUUM TRANSFER



JUMBO BAG FILLING STATION

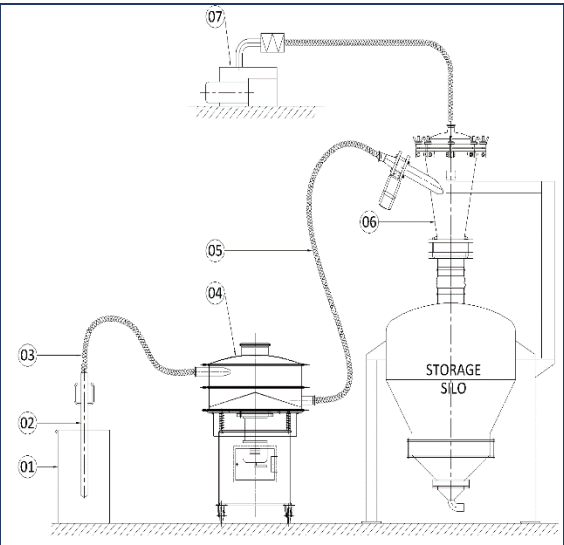

POWDER TRANSFER FOR SILO CHARGING VIA ONLINE SIEVING

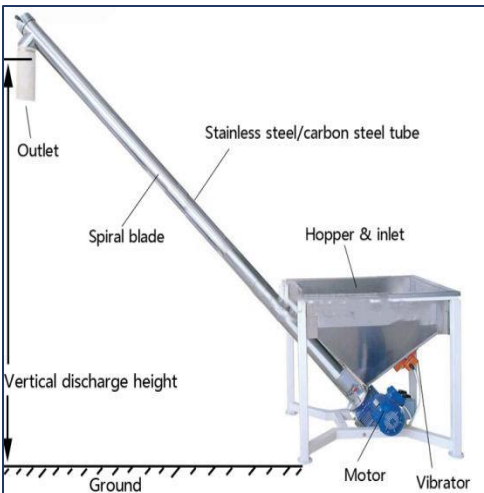

SCREW FEEDER

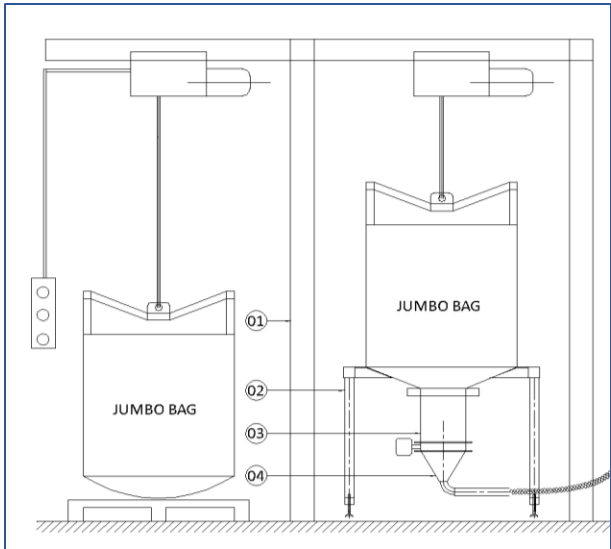

JUMBO BAG DISCHARGE STATION



SACK DISCHARGE STATION